



# GRINDSMART® 830XW

EN

# GRINDSMART® 830XW

Effective innovations in grinding solutions

The new GrindSmart®830XW, a combination of technology and innovation, is the result of intensive research work combined with our engineers' know-how in the design of precision grinding machines. This new model has been developed specifically for the grinding of cutting tools with surface finishes and cutting edges of a quality superior to market standards.

HYDROSTATIC + LINEAR TECHNOLOGY

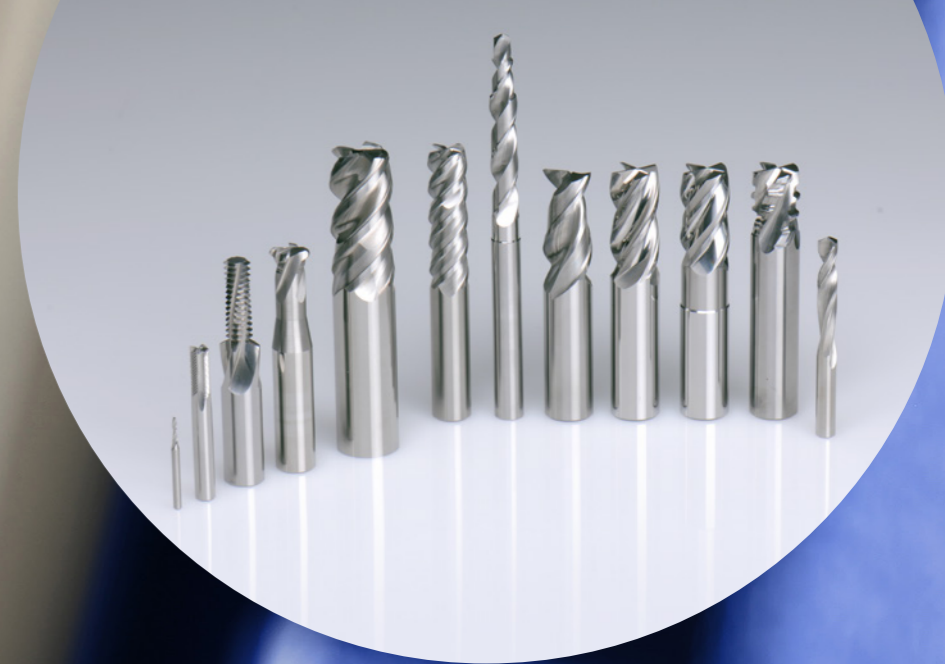

# GRINDSMART® 830XW

## HYDROSTATIC + LINEAR TECHNOLOGIES

The GrindSmart®830XW integrates the innovative combination of hydrostatic technology and linear motors to produce large and small series with 6 axes interpolated simultaneously. This concept provides an exceptionally high degree of rigidity and dampens vibrations that naturally occur during grinding, thereby increasing the life of the grinding wheels and guaranteeing surface finishes and sharp cutting edges that give users a real competitive advantage. Unattended production is an additional process that has been integrated into this machine to allow long-term manufacturing without human intervention.

The use of the same oil for the hydrostatic slides, cooling of grinding spindle, and coolant during grinding allows the machine to be kept at a constant temperature and provides a remarkably high level of thermal stability, both during setup and grinding.

The combination of these two technologies offers further advantages such as non-contact, non-stick and friction-free slide movements as well as reduced maintenance costs.



### 6-axis Fanuc Robot

- Capacity of 10 cassettes for up to 4'500 pieces
- Extreme flexibility



### Synchronous direct-drive grinding spindle

- Constant wheel rotation independent from spindle load
- Perfect and homogeneous surface finish
- Low power consumption



### 6-axis kinematic

- Constant grinding point for relief operations on ballnose, radii and form tools
- Maximum freedom in axis movements due to the 6-axis design and the total symmetry of the spindle axis (A)



### Rollomatic VirtualGrind®Pro

- Full software package included
- Free upgrades during the entire machine life time

### Smart Connectivity, Industry 4.0

- In-process tool measuring system to enhance the autonomy without human intervention
- RMonitor for remote production management
- Monitoring software also available on smartphones



### Ultra-compact 15-position wheel/nozzle changer

- Wheel pack and nozzle change under 11 seconds
- Tool unload/load simultaneously during wheel change
- Lean manufacturing
- No additional footprint

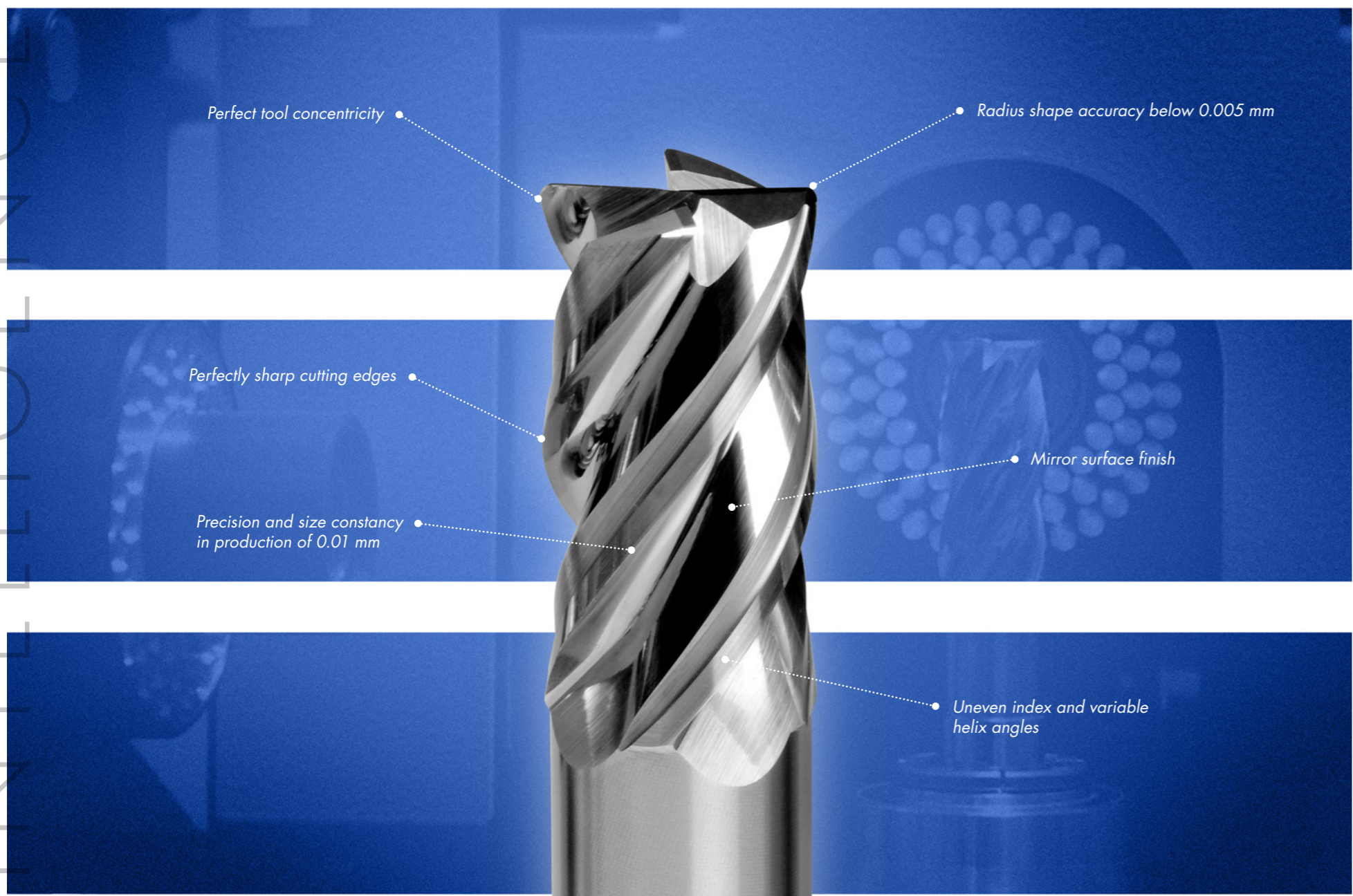

Perfect tool concentricity

Radius shape accuracy below 0.005 mm

Perfectly sharp cutting edges

Mirror surface finish

Precision and size constancy in production of 0.01 mm

Uneven index and variable helix angles

**GRINDSMART®830XW TECHNICAL DATA (MM)**

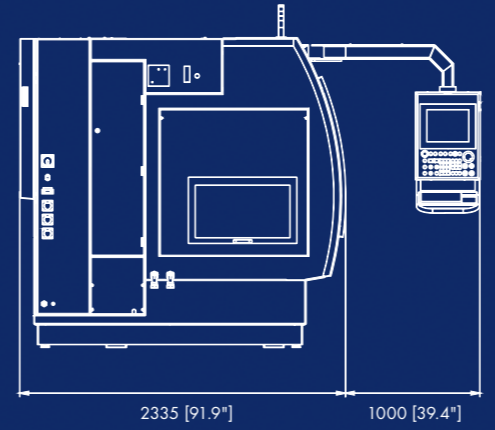
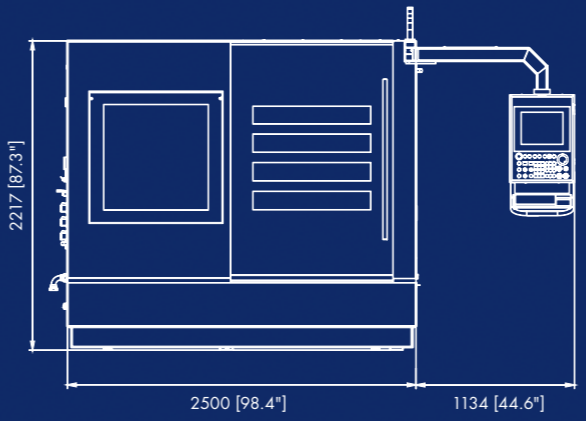

<b>GRINDING RANGE</b>	Ø 1.0 – 32.0 mm (.04" – 1.25")
<b>CONTROL</b>	FANUC 30iMB
X axis Stroke	320 mm (12.6")
Fast travel	12 m/min. (473"/min.)
Encoder type	Absolute linear scale
Resolution	0.00001 mm (.0000004")
Y axis Stroke	200 mm (7.87")
Fast travel	12 m/min. (473"/min.)
Encoder type	Absolute linear scale
Resolution	0.00001 mm (.0000004")
Z axis Stroke	400 mm (15.7")
Fast travel	12 m/min. (473"/min.)
Encoder type	Absolute linear scale
Resolution	0.00001 mm (.0000004")
A axis Stroke	-30° to 210° (240°), direct drive
Fast rotation	10800°/min.
Encoder type	Absolute optical encoder
Resolution	0.00001°
B axis Stroke	-30° to 210° (240°), direct drive
Fast rotation	10800°/min.
Encoder type	Absolute optical encoder
Resolution	0.00001°
C axis Stroke	Tool rotation, direct drive
Fast rotation	1000 r.p.m.
Encoder type	Absolute optical encoder
Resolution	0.00001°

<b>GRINDING MOTOR SYNCHRONOUS</b>	
Power	11 kW (15 HP), direct drive
Peak Power	14 kW (19 HP)
Rotation speed	500 – 8000 r.p.m.
Grinding wheels	Ø Max. 175 mm (7")
<b>WHEEL CHANGER SMARTCHANGER</b>	
Wheel pack capacity	15
Number of wheels per pack	4
Attachment	HSK50E
<b>CLAMPING</b>	
Clamping system	Adapters Schaublin and Nann
Clamping range	Ø 3.0 – 32.0 mm (.012" – 1.25")
Clamping type	Pneumatic
<b>ROBOT LOAD &amp; UNLOAD</b>	
Number of tools	Up to 4500 (10 cassettes)
Shank diameter	Ø 3.0 – 32.0 mm (.012" – 1.25")
Max. overall length	450 mm (18")
Clamping	Pneumatic
<b>TOOL SUPPORTS (OPTION)</b>	
Shank support	«V» clamping, Pneumatic
Cutting portion support	«V» or Half moon, Pneumatic
<b>MACHINE</b>	
L x W x H	2200 x 2500 x 2200 mm (86.6" x 98.4" x 86.6")
Weight	6200 kg (12125 lbs)
Total power	Maximum 27 kW 3 x 400V/45A

\* Specifications are subject to change without notice

[www.rollomaticsa.com](http://www.rollomaticsa.com)