



# NEXTAGE

EN



# NEXTAGE®

## NEXTAGE® ROBOT, A TRUE WORKING PARTNER

The new humanoid industrial robot, even more efficient, can easily be placed where a person usually operates and use its head and two arms, equipped with cameras, to take over any tedious, dangerous or repetitive tasks, allowing workers to focus on areas that require creativity and so generate greater added value.

Users can control and teach NEXTAGE® what to do with a visual and user-friendly interface.

It can be teamed up with conventional industrial robots or any other specialized equipment and can be considered a true working partner.

## NEXT-GENERATION INDUSTRIAL ROBOT

NEXTAGE® is a new type of industrial robot which, given its frame and size, can perform tasks in locations that are difficult for traditional robots to access. It can be installed with ease without the need to redesign production lines.





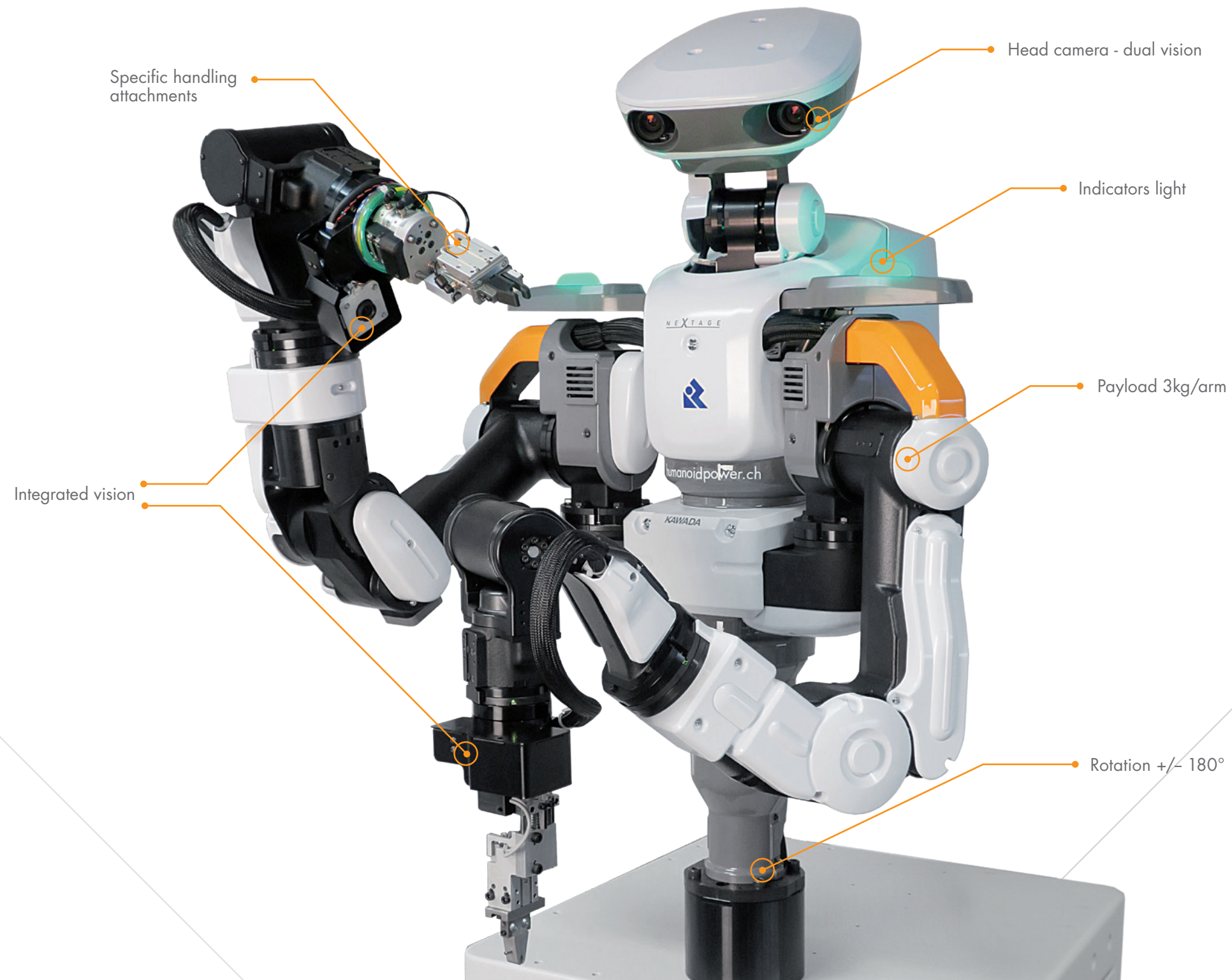

Specific handling attachments

Head camera - dual vision

Indicators light

Payload 3kg/arm

Integrated vision

Rotation +/- 180°

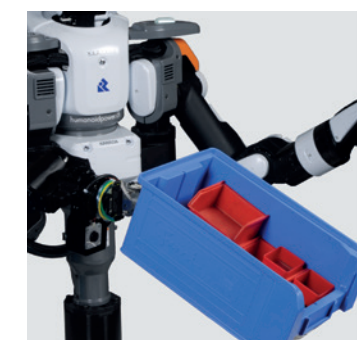

Load capacity

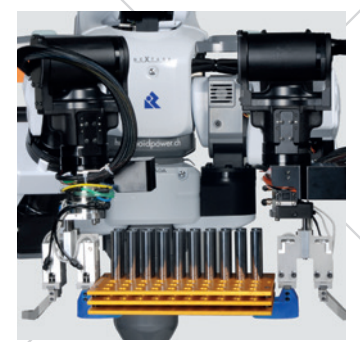

Load capacity

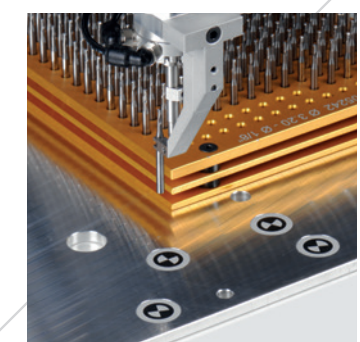

Cross markers



Specific handling attachments



Specific handling attachments

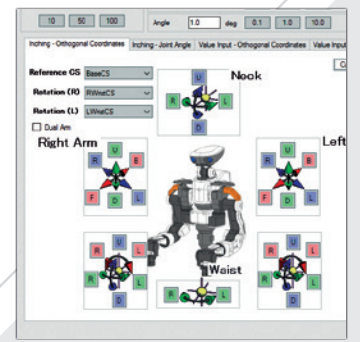

Control software

## SETTING NEW STANDARDS FOR THE MANUFACTURING ENVIRONMENT

### HEAD CAMERA - DUAL VISION

The two cameras attached to the robot head detect changes in the work environment and allow the robot to respond to changes on the production line or handle simple installations. With its global vision there is no need to reattach the robot when it is out of alignment with the current workflow. The robot can attain 3D coordinates with high precision by positioning "cross markers" that allow it to maneuver effortlessly under various conditions.

### INTEGRATED VISION ALONGSIDE ARM MOVEMENTS AND LOAD CAPACITY

By using the arm's full range of motion, cameras attached to the end of both robotic arms help determine the specific position of the object being worked on by capturing a two-dimensional image of it. With a load capacity of 3kg per arm, the robot is able to handle a variety of applications.

### HANDLING ATTACHMENTS AND TOOL CHANGER HOLDER

High-precision tool handling attachments are designed and manufactured by HumanoidPower Division according to your specific application. NEXTAGE® will automatically change each attachment while further handpieces are stored in an external attachment holder during any work cycle.

### HIGH RANGE OF MOTION

Thanks to its considerable flexibility of movement, NEXTAGE® can rotate one turn on itself, distributed between two +/- 180° respectively.

### QUALITY CONTROL SOFTWARE

The accompanying software provides visibility and usability, making the operation and instruction of NEXTAGE® easy with an image recognition system. The HumanoidPower Division will take care of the specific programming adapted to your projects as well as the necessary training for your automation projects.

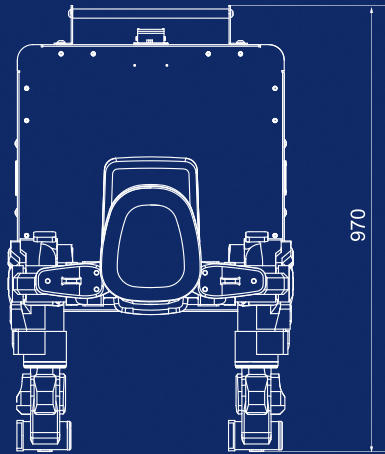

# SPECIFICATIONS

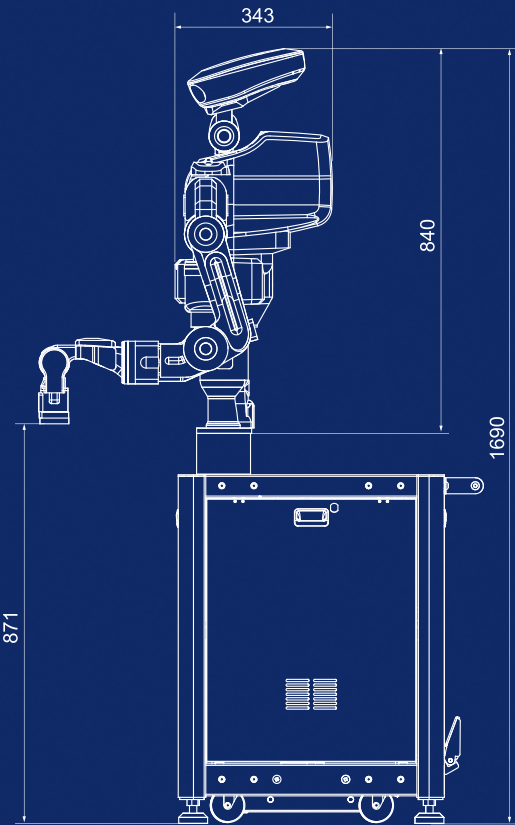
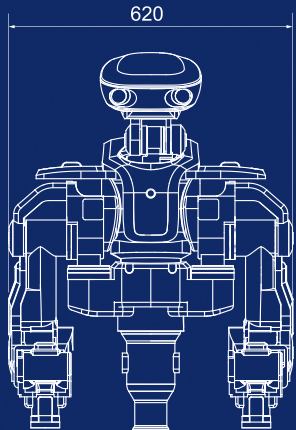

## SIZE

620 x 970 x 1'690 mm (24.4" x 38" x 66.5")

## DEGREE OF FREEDOM (DOF)

15 axes (6/arm, 2 head, 1 waist)

## MOTION RANGE

+/- 180°

Easy to move (on rollers)

## POSITIONING ACCURACY

+/- 30 microns

## CAMERAS

4 integrated cameras (1/arm, 2 head)

Color and shape recognition

## PAYLOAD

3kg/arm (hand included)

## APPLICATION CHANGE

Each arm is equipped with a tool loader

## LIGHTING

LED integrated in each arm

## INDICATORS LIGHT

Placed on its shoulders, they specify the state of the robot

## MANUFACTURER

Kawada Robotics Corporation, Japan

Manufacturer's EC declaration

\* Specifications are subject to change without notice

