

# Strausak **ONE**

Adaptive Grinding Solutions

EN

# STRAUSAK®

# ADAPTIVE GRINDING SOLUTIONS

Strausak develops and produces scalable equipment for professional cutting tool manufacturers. Experience a revolution in CNC tool grinding technology with the Strausak ONE, the universal solution for precision tool manufacturing.

From complex geometries to high-speed production, the Strausak ONE empowers manufacturers to achieve exceptional results with ease. With its seamless integration of advanced features such as robotic automation, multi-axis grinding capabilities, and intuitive programming interfaces, the Strausak ONE redefines what's possible in CNC tool grinding.



Revolutionize your tool grinding with

**numroto**®

Numroto makes tool programming simple and efficient, leading to superior results.

## WIDE APPLICATION RANGE

The extensive range of equipment available ensures efficient grinding of a wide range of tools, thanks to its remarkable versatility.

- Production or resharpening
- Efficient up to Ø 32 mm (1.26")
- HSS, carbide, or ceramic
- Fluting length up to 425 mm (16.73")
- Cutting up to Ø 170 mm (6.7")
- Cylindrical grinding up to Ø 250 mm (9.8")



# KINEMATICS & ERGONOMICS

The Strausak ONE is a 5-axis CNC-tool grinder in which all the direct-drive axes can be interpolated simultaneously. Its kinematics stand out for the ample machining strokes provided in relation to its overall dimensions.

## BEST ERGONOMICS

From an ergonomic point of view, it offers extremely short distances for access to the settings areas, facilitated by integrating the workhead on a linear axis directed towards the operator. The grinding wheel axis is suspended to ensure maximum machining freedom and easy removal of contaminants. The robot is strategically positioned so as not to interfere with access to the settings area.

Setup times are reduced to their minimum thanks to the unmatched access to the embedded equipment and an adjustable operating panel and its mobile remote control.

## BIG ACHIEVEMENT IN A SMALL FOOTPRINT

Modern workshops need flexibility, efficient floorspace use, lean processes, short setups, and small machines.

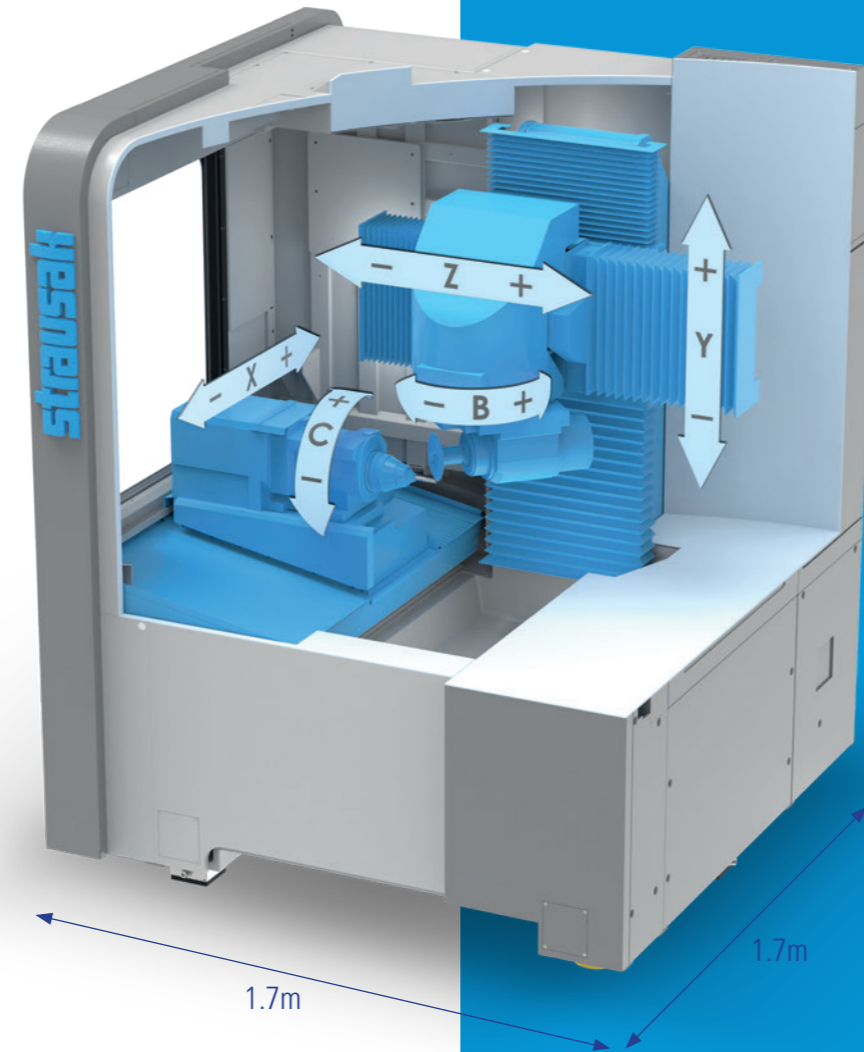

# DIRECT DRIVE TECHNOLOGY

Easily reach the best precision and efficiency with state-of-the-art direct drive motors that deliver uncompromising performance, eliminating backlash and wear, and ensure precise control over grinding operations. Experience smoother operation, faster acceleration, and higher torque, resulting in superior surface finishes and reduced cycle times. The result is uninterrupted production and easy maintenance.

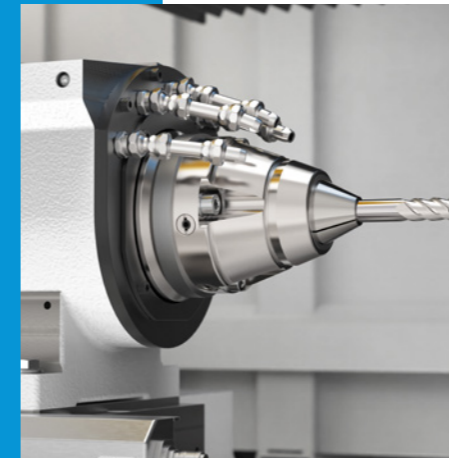

## ROTATING WORKHEAD (C-AXIS)

- Direct drive + encoder
- Liquid cooling
- 360° + of rotation
- 2'000 rpm
- ISO 50 interface
- Automatic clamping
- 5 integrated coolant jets

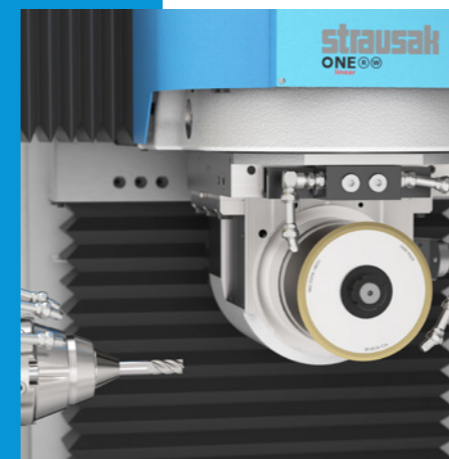

## SPINDLE HEAD (B-AXIS)

- Direct drive + encoder
- Liquid cooling
- 340° of rotation

## FULL DIRECT DRIVE

- 5x direct drives
- 5x direct position measuring
- No wear, no backlash
- Better dynamic
- Better path accuracy

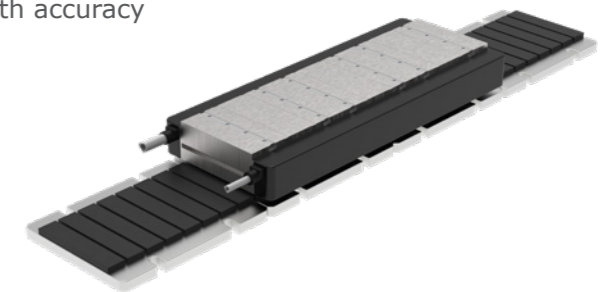
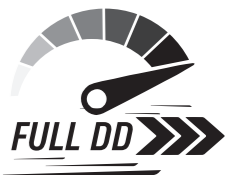



# GRINDING SPINDLES & PROBES

## MAIN SPINDLE

Performant spindle ensures smooth, vibration-free operation, minimizing tool wear and maximizing surface finish consistency. With optimal rotational speed and torque delivery, it empowers operators to tackle even the most challenging materials with ease, delivering results that meet the strictest tolerances.

- 12'000 rpm
- HSK 63F (compatible HSK 50E)
- 10 or 24 kW S1 (28 kW S6 60% 2min)
- Up to 28 Nm S1 (33 Nm S6 60% 2min) – synchronous

## HIGH FREQUENCY SPINDLES

Add a high-frequency spindle to process pocket or internal grinding operations. Its rapid rotations deliver the appropriate cutting speed to save grinding pins from premature wear and provide nice surface finish.

## 60'000 RPM SPINDLE

- 3 kW / 1 Nm
- Automatic HSK 25 clamping
- 4x magazine pin changer

## 100'000 RPM SPINDLE

- 0.5 kW / 0.084 Nm
- Automatic collet clamping
- 4x robot pin changer

## INTEGRATED TOOL & WHEEL PROBE

Before the first cut, exact probing ensures accuracy and efficiency, safeguarding against errors and minimizing material waste.

- 3D automatic tool probe with multi-tip stylus
- 3D automatic wheel probe
- In-process measurement
- Automatic compensation

# WHEEL MANAGEMENT

## AUTOMATIC WHEEL CHANGERS

Maximize efficiency and quality in grinding operations with automatic wheel change and meticulous wheel maintenance. Seamlessly swap wheel packs for diverse tasks while ensuring consistent performance and prolonging wheel lifespan.

- Capacity: 4, 8 or 12 wheel packs
- ~ 12 seconds wheel changing time
- Wheel Ø up to 150 mm (5.9")

## COOLANT DISTRIBUTION

Optimal coolant distribution is decisive in grinding. It dissipates heat, reduces friction, and flushes away debris, preserving wheel integrity and enhancing surface quality. Exchangeable coolant manifolds ensure efficient coolant distribution for each grinding wheel.

- Simultaneous to wheel changes
- Up to 6 jets per manifolds
- High flow coolant supply

## IN PROCESS WHEEL DRESSING

- 16'000 rpm
- 2.3 kW / 1,3 Nm
- Programmable wipe dressing
- Automatic wheel profiling based on DXF

## AUTOMATIC WHEEL CLEANING

- Foldable stick stone holder
- Sticking via plunge or oscillation
- Automatic monitoring of stone condition
- up to 25 x 25 x 150 mm

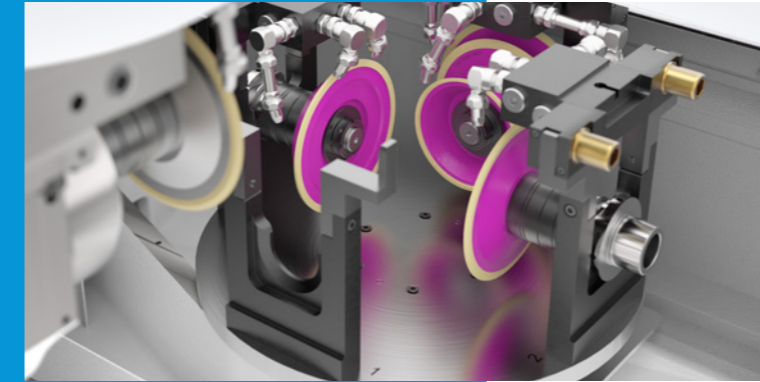
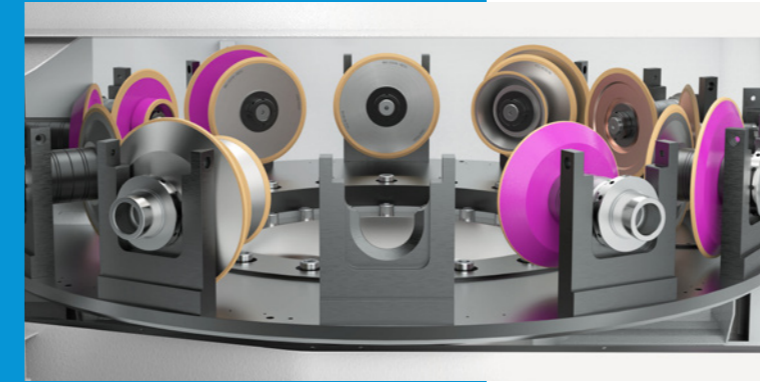
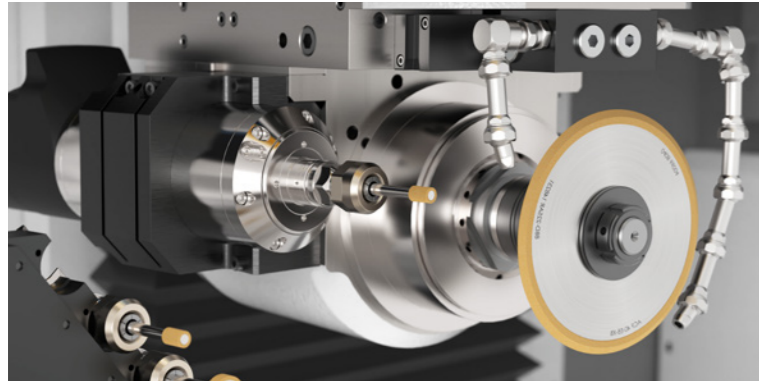
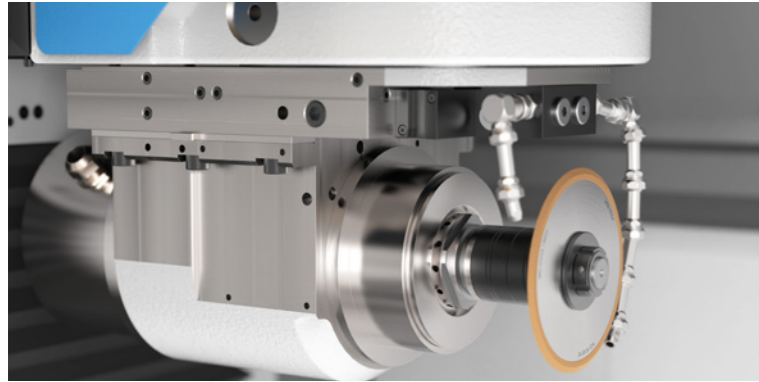



# TOOL SUPPORTS

# SUPPORT MODULES

## CLAMPING TABLE

The optional clamping table allows for setups using various tool supports to ensure a stable and chatter free behavior during grinding operation. Its unique geometry has been optimized in term of weight and rigidity and keeps a good grinding wheel access to the workpiece.

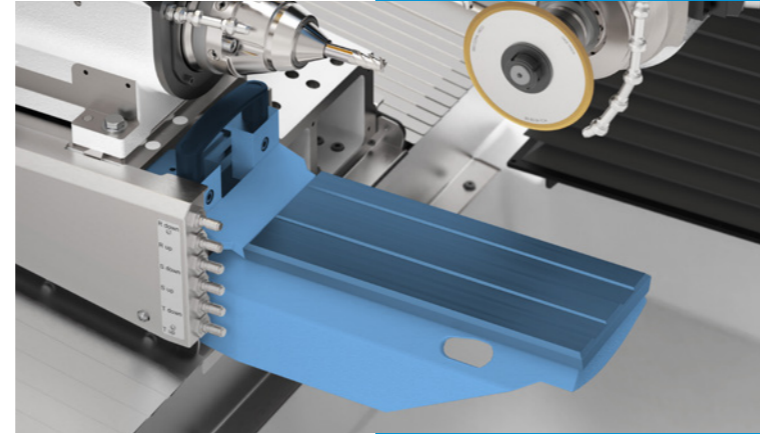

## TRAVELLING STEADY REST

The travelling steady rest enables stable and precise production of long tools. Mounted on an additional interpolated axis, it ensures a support that is constantly positioned under the grinding point, as well as stable geometry over the entire length of the tool. Combined with a self-centring steady rest, it provides rigid support when grinding conical geometries. Its automatic positioning saves considerable time when producing batches of tools of varying lengths or cross-sections. Finally, this support automatically retracts under the chuck when an operation requires omnidirectional access to the tool.

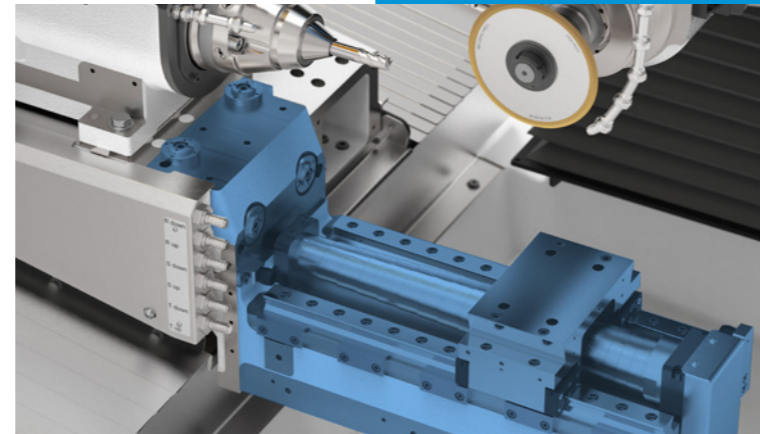

## RUN-OUT OPTIMIZER

This guiding system with automatic retention finger improves the stability of the runout over tool loadings.

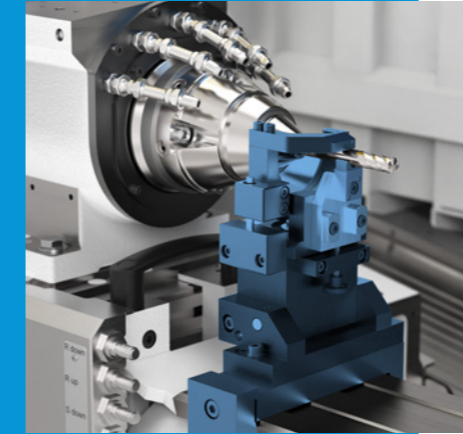

## AUTOMATIC STEADY REST

Used to support and hold in position long workpieces that could be deflected during the grinding process. Half-rounds or prisms can be used depending on the type of the workpiece and the task.

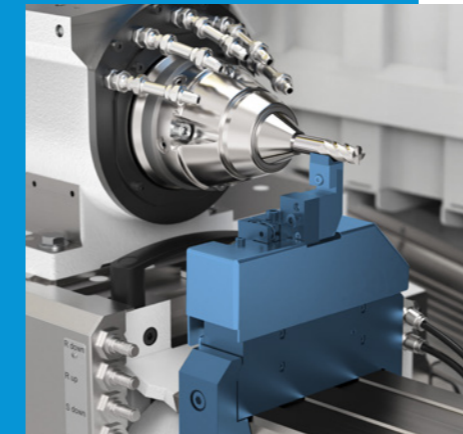

## CENTERING STEADY REST

This AROBOTECH steady rest is a highly accurate solution to prevent long and slender workpieces from vibration, deflection or chattering that could occur during machining. It is also self-centering to the tool geometry which reduces unproductive setup time.

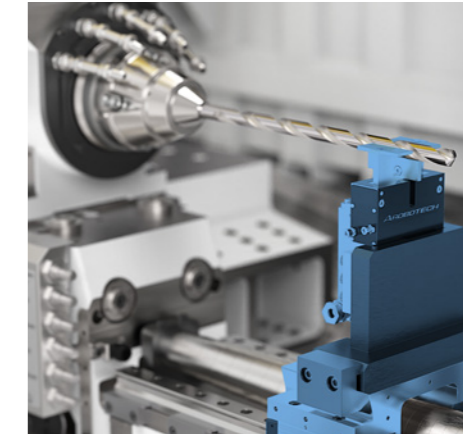

## AUTOMATIC TAILSTOCK

This automatic tailstock supports and stabilizes the opposite end of a workpiece during the machining process to ensure precision and accuracy in the final geometries.

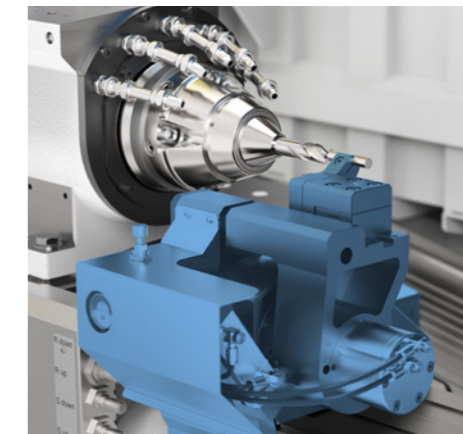

## RETAKE VICE

Designed to allow quick and precise repositioning of workpieces for subsequent machining operations. Its rigid and rapid clamping makes it ideal for setups where multiple machining steps are required (bar production, finishing, etc.)

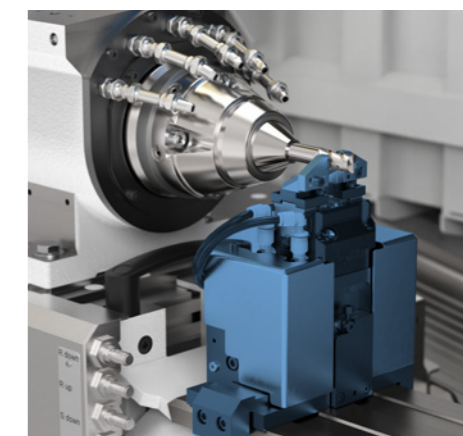



# AUTOMATIC TOOL LOADERS

# CUSTOMER CARE

The Strausak ONE machine adapts to the degree of automation required by its user, whether to enhance productivity or autonomy. Various solutions are available to automate the loading of tools with cylindrical geometry or inserts.

## PICK-UP LOADER SIMPLE AND EFFICIENT

- Capacity up to 500 units
- Single gripper Ø 1 - Ø 32 mm
- Lmax = 200 mm
- ~ 40 seconds loading time



## ROBOT LOADER VERSATILE AND PERFORMANT

- Capacity up to 1000 units
- Double gripper Ø 1 - Ø 32 mm
- Lmax = 400 mm
- ~ 12 second loading time
- Tool flip / tool trunk
- Sleeve exchange



## CHAIN LOADER THE FLEXIBLE SOLUTION

- Capacity up to 155 units
- Single gripper Ø 1 - Ø 32 mm
- Ø max = 155 x Ø 40 mm (77x Ø 90 mm)
- Lmax = 320 mm



## INSERT LOADER THE CLEVER INTEGRATION

- Carbide inserts with holes
- Front side / back side clamping
- Integrated head nails
- Customizable pallets
- Automatic run-out compensation
- Magnetic gripper



The Strausak teams are here to advise and support you in your production projects. From the design of machining solutions to the installation of the machine and the training of your operators by our highly qualified staff.

- + Reactive and accurate Hotline for a competent and fast assistance
- + Consumables, spare parts, tooling & accessories in stock world-wide
- + Technical support for machine installation, calibration & connection
- + Application & programming trainings
- + Test grinding of acceptance parts
- + Preventive maintenance

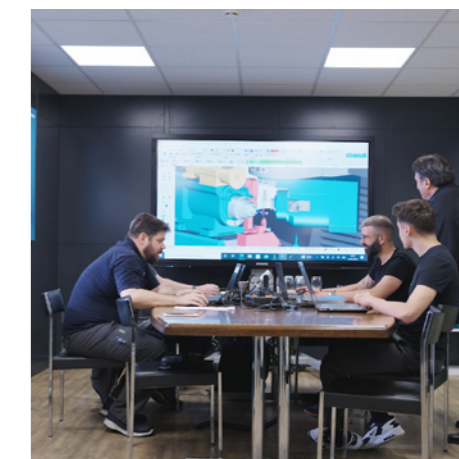

## SPECIFICATIONS

### Grinding Capacity

Max. tool Ø (production)	32 mm	1.26"
Max. tool Ø (resharpening)	170 mm	6.70"
Max. tool length	700 mm	19.70"
Max. fluting length	425 mm	16.73"

### Workpiece Spindle

Clamping / Unclamping	pneumatic
Attachment	ISO 50 (SK 50)

### Grinding Spindle

Attachment	HSK 63F (HSK 50E)	
SMax. speed	12 000 rpm	
Power (S1)	10 (24) kW	14 (32) HP
Torque (S1)	12 (28) Nm	9 (21) ft-lbs
Grinding wheel Ø	150 mm	6"

### Machine

Dimensions (L x W x H)	1,7 x 1,7 x 2,0 m 67" x 67" x 79"	
Weight	3 700 kg	8,140 lbs

### Rotary Axes

B-axis range	340°
B-axis resolution	± 2.5"
C-axis range	∞
C-axis resolution	± 2.0"
C-axis rotation speed	2 000 rpm

### Linear Axes

Rapid feedrate	30 m/min
Acceleration	5 m/s <sup>2</sup>
Resolution	0.00001 mm

### CNC-Control

Type	NUM Flexium+
Software	NUMROTOplus®

### Wheel Changer

Capacity	4x (8x / 12x)
Attachment	HSK 63F (HSK 50E)

